

Flygt PP 4220.611/.690

Table of Contents

| | | |
|-----|----------------------------------|---|
| 1 | Introduction..... | 2 |
| 1.1 | Specially approved products..... | 2 |
| 2 | Product Description..... | 3 |
| 2.1 | The data plate..... | 3 |
| 2.2 | Approvals..... | 3 |
| 2.3 | Product denomination..... | 4 |
| 3 | Exploded View..... | 6 |
| 3.1 | Drive unit..... | 6 |
| 3.2 | Hydraulic unit..... | 7 |
| 3.3 | Installation components..... | 8 |
| 4 | List of Parts..... | 9 |
| 4.1 | 4220.611/.690..... | 9 |

1 Introduction

Purpose of this manual

The purpose of this manual is to provide necessary information on spare parts and accessories order.

Disclaimer

Always use genuine Flygt parts. The use of other spare parts or accessories can invalidate any claims for warranty or compensation. Xylem does not take any responsibility for damages that are caused by the use of non-original parts. For more information, contact your local sales and service representative.

Data for ordering spare parts

The following information is needed for spare part orders:

- Serial number of the product
- Part number
- Quantity of bulk material, see * in tables

1.1 Specially approved products

Qualification of personnel

Only Xylem or Xylem-authorized service personnel may undertake repair work on specially approved products.

Dimensional accuracy inspection

Spare parts marked with (Ex) after the part number are subject to dimensional accuracy inspection when used in specially approved products.

2 Product Description

2.1 The data plate

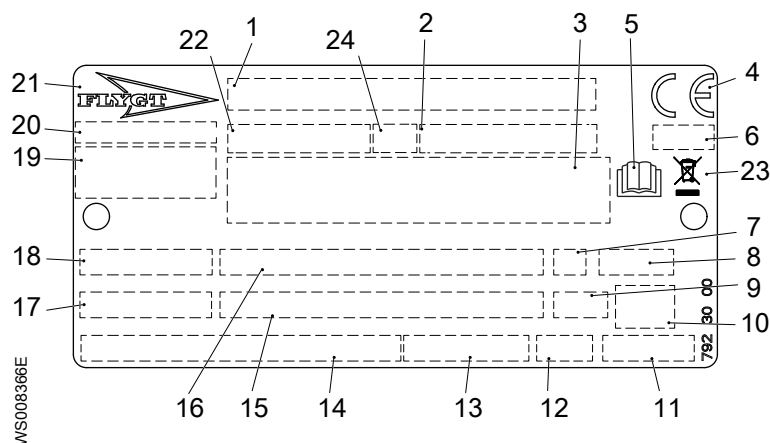

1. Serial number, see [Product denomination](#) on page 4
2. Product number
3. Additional information
4. CE-marking
5. Read installation manual
6. Notified body (only for EN-approved Ex products)
7. Duty class
8. Degree of protection
9. Thermal class
10. Maximum submergence
11. Product weight
12. Direction of rotation: L=left, R=right
13. Speed
14. Minimum rated voltage/rated current – maximum rated voltage/rated current
15. Maximum ambient temperature (2), rated shaft power (2)
16. Maximum ambient temperature (1), rated shaft power (1)
17. Power factor
18. Phase, type of current, frequency
19. Manufacturer
20. Country of origin
21. Brand
22. Sales denomination
23. WEEE-Directive symbol
24. Hydraulic end, type of installation

2.2 Approvals

Product approvals for hazardous locations

| Product | Approval |
|----------|---|
| 4220.690 | European Norm (EN) <ul style="list-style-type: none"> • ATEX Directive • EN IEC 60079-0:2018, EN 60079-1:2014, EN ISO 80079-36:2016, EN ISO 80079-37:2016 •  II 2 G Ex db h IIB T3/T4 Gb |
| | IEC <ul style="list-style-type: none"> • IECEx scheme • IEC 60079-0:2017, IEC 60079-1:2014-06, ISO 80079-36:2016, ISO 80079-37:2016 • Ex db h IIB T3/T4 Gb |
| | FM (FM Approvals) <ul style="list-style-type: none"> • Explosion proof for use in Class I, Div. 1, Group C and D |

| Product | Approval |
|---------|---|
| | CSA Ex • Explosion proof for use in Class I, Div. 1, Group C and D |

EN approval plate

This illustration describes the EN approval plate and the information that is contained in its fields.

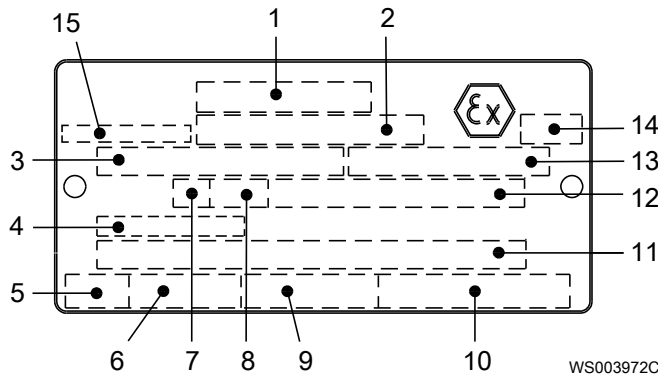

1. Approval
2. Approval authority and Approval number
3. Approved drive unit
4. Cable entry temperature
5. Stall time
6. Starting current or Rated current
7. Duty class
8. Duty factor
9. Input power
10. Rated speed
11. Additional information
12. Maximum ambient temperature
13. Serial number
14. ATEX marking
15. Country of origin

IEC approval plate

This illustration describes the IEC approval plate and the information that is contained in its fields.

International Norm; not for EU member countries.

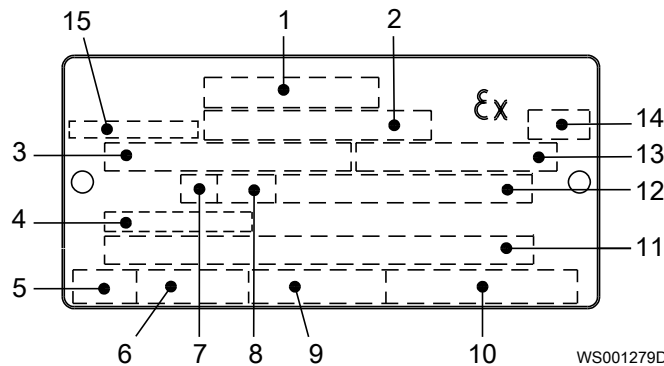

1. Approval
2. Approval authority and Approval number
3. Approved drive unit
4. Cable entry temperature
5. Stall time
6. Starting current or Rated current
7. Duty class
8. Duty factor
9. Input power
10. Rated speed
11. Additional information
12. Maximum ambient temperature
13. Serial number
14. ATEX marking
15. Country of origin

2.3 Product denomination

Reading instruction

In this section, code characters are illustrated accordingly:

X = letter

Y = digit

The different types of codes are marked up with a, b and c. Code parameters are marked up with numbers.

Codes and parameters

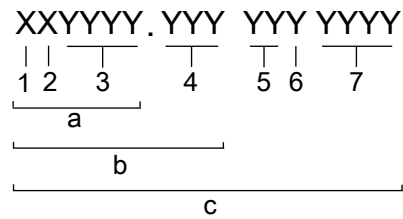

WS006265B

| Type of Callout | Number | Indication |
|-----------------|--------|----------------------|
| Type of code | a | Sales denomination |
| | b | Product code |
| | c | Serial number |
| Parameter | 1 | Hydraulic end |
| | 2 | Type of installation |
| | 3 | Sales code |
| | 4 | Version |
| | 5 | Production year |
| | 6 | Production cycle |
| | 7 | Running number |

3 Exploded View

3.1 Drive unit

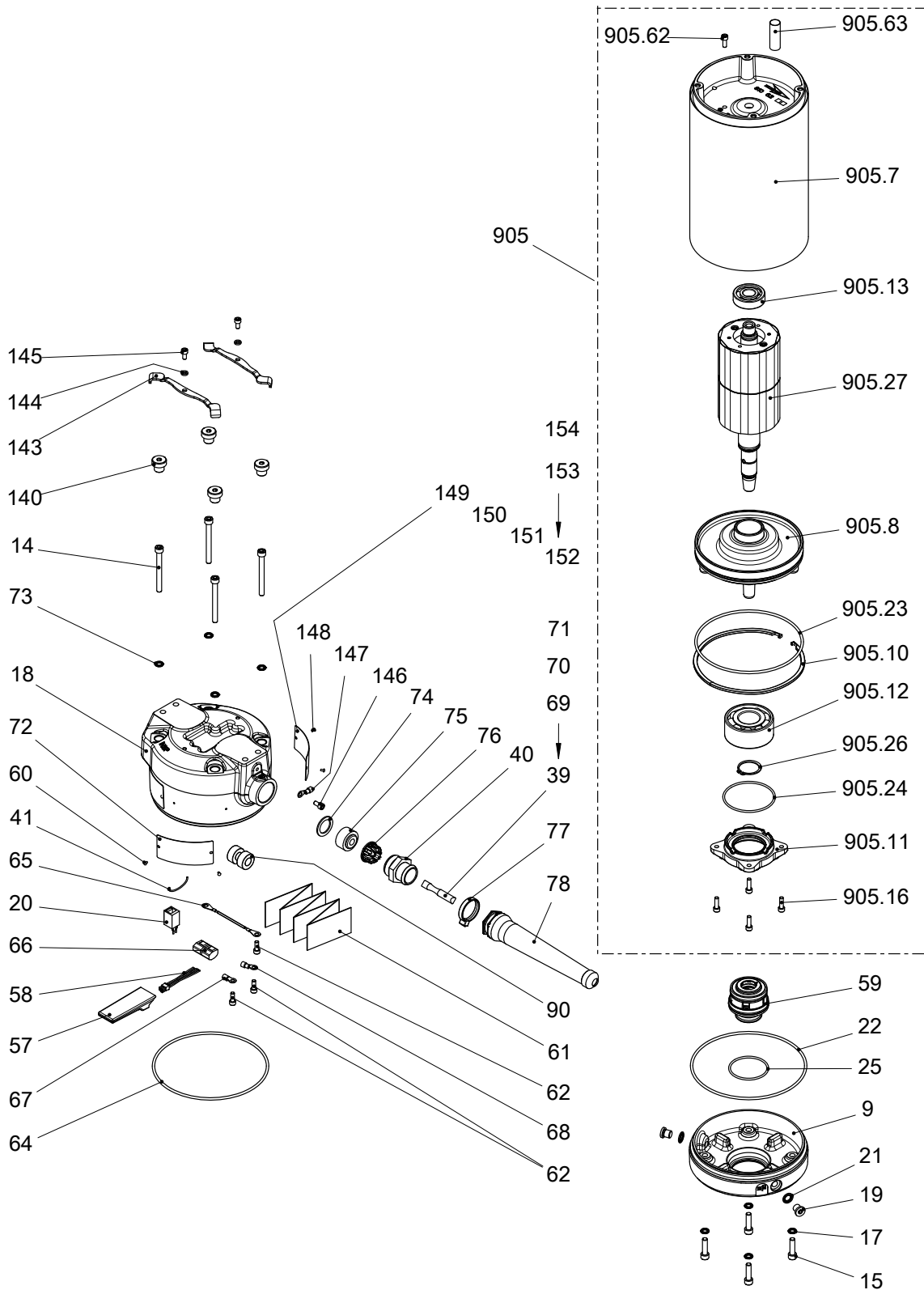

40966B

3.2 Hydraulic unit

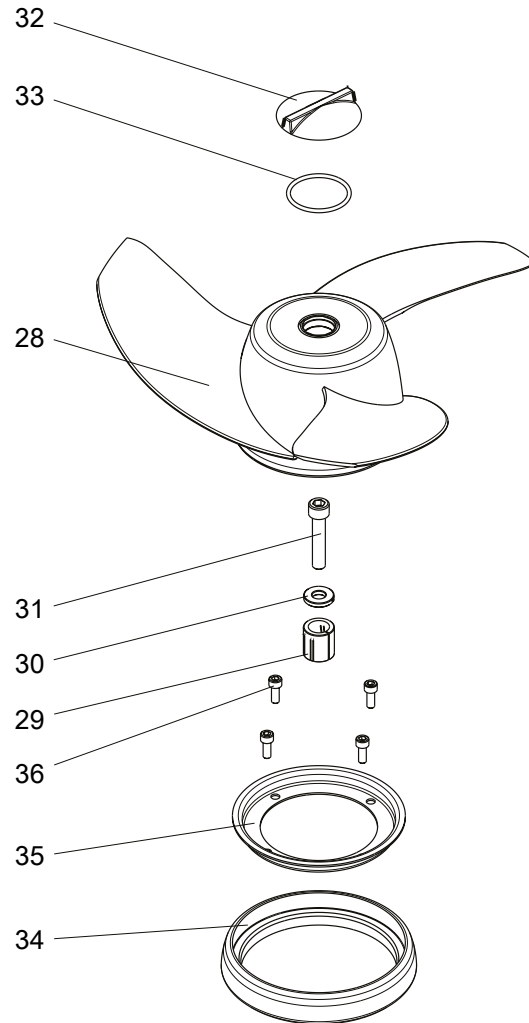

40962A

3.3 Installation components

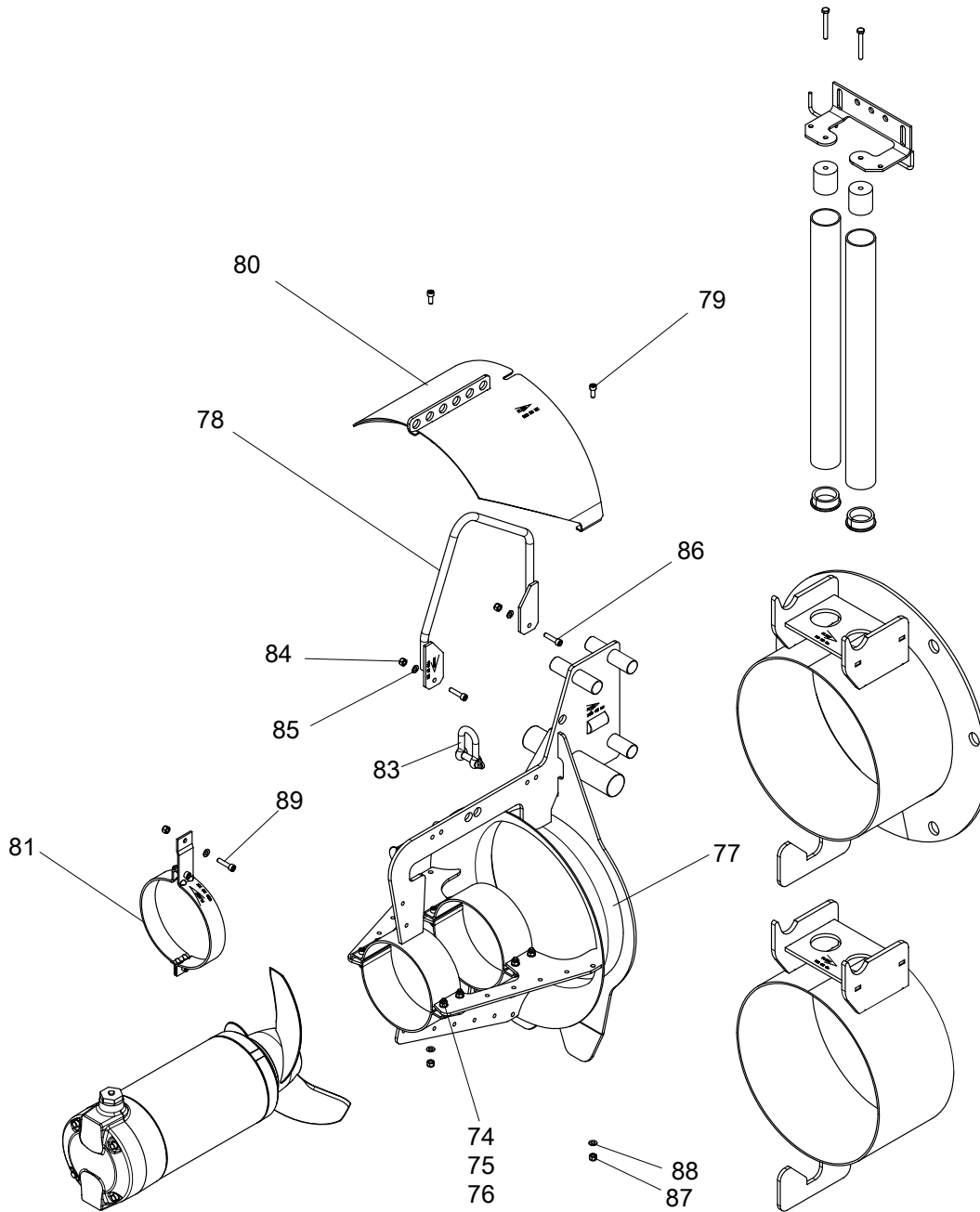

40960A

4 List of Parts

4.1 4220.611/.690

Table 1: 4220

| Pos. No | Part. No | Type | Denomination | Qty/Version | |
|---------|-----------|------|--|-------------|-----|
| | | | | 611 | 690 |
| 9 | 810 64 00 | (Ex) | Seal housing cover u | 1 | 1 |
| 14 | 85 03 45 | | Hex.socket hd screw ISO 4762 M 8 X110-A4-80 | 4 | |
| 14 | 85 07 37 | | Hex.socket hd screw ISO 4762 M8X80-A4-80 | | 4 |
| 15 | 83 03 02 | | Hex.socket hd screw M8X30- A4-70 | 4 | 4 |
| 17 | 583 32 00 | (Ex) | Seal washer | 4 | 4 |
| 18 | 810 70 34 | | Connect. hous.unit | 1 | |
| 18 | 810 70 36 | | Connect. hous.unit | 1 | |
| 18 | 810 70 42 | | Connect. hous.unit | 1 | |
| 18 | 810 70 48 | | Connect. hous.unit | 1 | |
| 18 | 810 70 19 | (Ex) | Connect. hous.unit | | 1 |
| 18 | 810 70 17 | (Ex) | Connect. hous.unit | | 1 |
| 18 | 810 70 21 | (Ex) | Connect. hous.unit | | 1 |
| 18 | 810 70 23 | (Ex) | Connect. hous.unit | | 1 |
| 19 | 85 05 78 | | Plug | 2 | 2 |
| 20 | 518 89 03 | (Ex) | Leakage sensor | 1 | 1 |
| 21 | 85 05 49 | | Seal washer | 2 | 2 |
| 22 | 85 03 17 | | O-ring 165.0 X 4.0 FPM | 1 | 1 |
| 25 | 82 71 71 | | O-ring 62X3.0 FPM | 1 | 1 |
| 28 | 810 40 00 | | Propeller compl. | 1 | 1 |
| 29 | 782 72 02 | | Clamping sleeve | 1 | 1 |
| 30 | 338 13 11 | | Plain washer 10.5X23.5X4 | 1 | 1 |
| 31 | 83 02 00 | | Hex.socket hd screw M10X50- A4-80 | 1 | 1 |
| 32 | 569 15 00 | | Protective plug | 1 | 1 |
| 33 | 82 80 97 | | O-ring 44.2X3 FPM | 1 | 1 |
| 34 | 810 45 00 | | Protective ring | 1 | 1 |
| 35 | 810 46 00 | | Holder | 1 | 1 |
| 36 | 83 02 75 | | Hex.socket hd screw M6X16- A4-70 | 4 | 4 |
| 38 | 592 04 00 | | Caution plate | 1 | 1 |
| 39 | 94 19 90 | | Motor cable subcab S3X2.5+3X2.5/3+S(4X0.5) | * | * |
| 40 | 462 45 00 | (Ex) | Gland screw Pr 37 | 1 | 1 |
| 40 | 791 15 00 | | Gland screw ISO G1 1/4" | 1 | 1 |
| 41 | 573 58 70 | | Single-core cable | 1 | 4 |
| 48 | 85 08 94 | | End sleeve | 4 | 4 |

4 List of Parts

| Pos. No | Part. No | Type | Denomination | Qty/Version | |
|---------|-----------|------|---|-------------|-----|
| | | | | 611 | 690 |
| 57 | 820 83 00 | | I/o unit | 1 | 1 |
| 58 | 824 95 00 | | Cable unit | 1 | 1 |
| 59 | 769 87 33 | | Mechanical seal dbl. AL203/ WCCR,WCCR/WCCR FPM | 1 | 1 |
| 59 | 769 87 34 | | Mechanical seal dbl. AL203/ WCCR,RSIC/RSIC FPM | 1 | 1 |
| 60 | 82 20 88 | | Drive screw 4X5-A2/A4 | 2 | 4 |
| 61 | 791 48 04 | | Connection plate | 1 | 1 |
| 62 | 83 02 75 | | Hex.socket hd screw M6X16- A4-70 | 4 | 4 |
| 64 | 85 03 17 | | O-ring 165.0 X 4.0 FPM | 1 | 1 |
| 65 | 573 58 20 | | Single-core cable | 1 | 1 |
| 66 | 83 42 67 | | Terminal block 600V/20A UL | 1 | 2 |
| 66 | 83 42 65 | | Terminal block 600V/20A UL | | 1 |
| 67 | 83 43 62 | | Cable lug UL/CSA 0.50-1.65 MM2 M6 | 1 | 1 |
| 68 | 85 10 24 | | Cable lug | 1 | 1 |
| 69 | 93 00 77 | | Shrink hose ID=6.4 MM | * | * |
| 70 | 94 03 33 | | Shrink hose ID=3.2 MM | * | * |
| 71 | 94 03 34 | | Shrink hose ID=6.4 MM | * | * |
| 72 | 792 30 00 | | Data plate | 1 | 1 |
| 73 | 583 32 00 | (Ex) | Seal washer | 4 | 4 |
| 74 | 82 27 27 | | Lock nut M8-A4-70 | 8 | 8 |
| | | | PP lifting handle Vortex shield short | | |
| | | | PP Vortex shield short | | |
| | | | PP PP lifting handle | | |
| 74 | 82 42 42 | | Plain washer 24.5X35X2-A4-70 | 1 | 1 |
| 75 | 82 35 74 | | Plain washer 8.4X16X1.8- A4-170HV | 8 | 8 |
| | | | PP PP lifting handle Vortex shield short | | |
| | | | PP Vortex shield short | | |
| | | | PP PP lifting handle | | |
| | | | PP | | |

| Pos. No | Part. No | Type | Denomination | Qty/Version | |
|---------|-----------|------|--|-------------|-----|
| | | | | 611 | 690 |
| 75 | 84 17 94 | | Seal sleeve (18)-20 MM NBR Cable and cable entry 20 m SUBCAB S3x2,5+3x2,5/3+S(4x0,5) Cable and cable entry 20 m SUBCAB S3x2,5+3x2,5/3+S(4x0,5) Thread: ISO G1 1/4 Cable and cable entry 10 m SUBCAB S3x2,5+3x2,5/3+S(4x0,5) Cable and cable entry 10 m SUBCAB S3x2,5+3x2,5/3+S(4x0,5) Thread: ISO G1 1/4 | 1 | 1 |
| 76 | 83 04 45 | | Hex.socket hd screw M8X35- A4-80 PP PP lifting handle Vortex shield short PP Vortex shield short PP PP lifting handle PP | 8 | 8 |
| 76 | 678 58 20 | (Ex) | Cable clip 18-(20) MM Cable and cable entry 20 m SUBCAB S3x2,5+3x2,5/3+S(4x0,5) Cable and cable entry 20 m SUBCAB S3x2,5+3x2,5/3+S(4x0,5) Thread: ISO G1 1/4 Cable and cable entry 10 m SUBCAB S3x2,5+3x2,5/3+S(4x0,5) Cable and cable entry 10 m SUBCAB S3x2,5+3x2,5/3+S(4x0,5) Thread: ISO G1 1/4 | 1 | 1 |
| 77 | 703 45 01 | (Ex) | Inlet cone compl. | 1 | 1 |
| 78 | 703 57 01 | (Ex) | Lifting handle compl | 1 | 1 |
| 79 | 83 04 48 | | Hex.socket hd screw M8X20- A4-80 | 2 | 2 |
| 80 | 693 24 01 | | Protect.disc compl. | 1 | 1 |
| 81 | 696 23 01 | | Handle unit | 1 | 1 |
| 81,1 | 82 27 27 | | Lock nut M8-A4-70 | 2 | 2 |
| 81,2 | 82 35 74 | | Plain washer 8.4X16X1.8- A4-170HV | 2 | 2 |
| 81,3 | 83 04 45 | | Hex.socket hd screw M8X35- A4-80 | 2 | 2 |
| 83 | 82 26 49 | | Shackle | 1 | 1 |
| 84 | 82 27 27 | | Lock nut M8-A4-70 | 2 | 2 |
| 85 | 82 35 74 | | Plain washer 8.4X16X1.8- A4-170HV PP PP lifting handle Vortex shield short PP PP lifting handle | 2 | 2 |
| 85 | 83 45 63 | | Cable holder | 1 | 1 |
| 86 | 83 04 45 | | Hex.socket hd screw M8X35- A4-80 | 2 | 2 |

| Pos. No | Part. No | Type | Denomination | Qty/Version | |
|---------|-----------|------|----------------------------------|-------------|--|
| | | | | 611 | 690 |
| 87 | 82 27 27 | | Lock nut M8-A4-70 | 3 | 3 |
| 88 | 82 35 74 | | Plain washer 8.4X16X1.8-A4-170HV | 3 | 3 |
| 89 | 83 04 45 | | Hex.socket hd screw M8X35-A4-80 | 1 | 1 |
| 90 | 83 95 06 | | Electrical filter | 2 | 2 |
| 140 | 828 38 00 | (Ex) | Screw | | 4 |
| 143 | 828 81 00 | (Ex) | Bracket | | 2 |
| 144 | 85 07 38 | | Lock washer | | 2 |
| 145 | 83 02 73 | | Hex.socket hd screw M6X12-A4-70 | | 2 |
| 146 | 83 02 73 | | Hex.socket hd screw M6X12-A4-70 | | 1 |
| 147 | 85 10 24 | | Cable lug | | 1 |
| 148 | 82 20 88 | | Drive screw 4X5-A2/A4 | | 2 |
| 149 | 796 04 00 | (Ex) | Certificate plate | | 1 |
| 150 | 796 04 01 | (Ex) | Certificate plate | | 1 |
| 151 | 796 03 10 | (Ex) | Certificate plate | | 1 |
| 152 | 801 03 04 | (Ex) | Name plate | | 1 |
| 153 | 801 04 00 | | Caution plate | | 1 |
| 154 | 83 45 59 | | Cable tie 200X2.4 PA 6/6-55+105 | | 1 |
| 400 | 667 40 00 | | Sticker | 2 | 2 |
| 401 | 726 37 00 | | Caution label | 2 | 2 |
| 402 | 820 22 00 | | Sticker | 2 | 2 |
| 800 | 85 03 41 | | O-ring kit | 1 | 1 |
| 900 | 810 76 00 | | Basic repair kit | 1 | 1 |
| 900 | 810 76 01 | | Basic repair kit | 1 | 1 |
| 901 | 90 17 52 | | Oil ISO VG 32 | * | * |
| 905 | 810 84 00 | | Motor unit | 1 | |
| | | | | | Maximum power: 2,20 kW / 3 HP Maximum current: 4,60 A |
| | | | | | Maximum power: 1,50 kW / 2 HP Maximum current: 3,20 A |
| | | | | | Maximum power: 1,50 kW / 2 HP Maximum current: 3,10 A |
| 905,7 | 810 62 00 | | Stator housing unit | 1 | |
| 905,8 | 810 65 00 | | Bearing holder | 1 | |
| 905,10 | 810 55 00 | | Retaining ring | 1 | |
| 905,11 | 797 44 00 | | Bearing cover | 1 | |
| 905,12 | 83 30 17 | | Ball bearing 35X80X34.9 MM | 1 | |
| 905,13 | 83 33 13 | | Ball bearing 20X52X15 MM | 1 | |
| 905,16 | 82 00 15 | | Hex.socket hd screw M6X20-A2-70 | 4 | |
| 905,23 | 85 03 17 | | O-ring 165.0 X 4.0 FPM | 1 | |
| 905,24 | 81 78 99 | | O-ring 74.61X3.53 NBR | 1 | |
| 905,26 | 82 59 03 | | Retaining ring SGA 35 | 1 | |
| 905,27 | 852 32 00 | | Shaft unit | 1 | |

| Pos. No | Part. No | Type | Denomination | Qty/Version | |
|---------|-----------|------|--|-------------|-----|
| | | | | 611 | 690 |
| 905,63 | 836 39 00 | | Insulating hose | 1 | |
| 905 | 810 84 06 | | Motor unit Maximum power: 3 kW / 4 HP Maximum current: 6,50 A Maximum power: 3 kW / 4 HP Maximum current: 5,90 A Maximum power: 4 kW / 5,50 HP Maximum current: 7,90 A Maximum power: 4 kW / 5,50 HP Maximum current: 7,40 A | 1 | |
| 905,7 | 810 62 06 | | Stator housing unit | 1 | |
| 905,8 | 810 65 00 | | Bearing holder | 1 | |
| 905,10 | 810 55 00 | | Retaining ring | 1 | |
| 905,11 | 797 44 00 | | Bearing cover | 1 | |
| 905,12 | 83 30 17 | | Ball bearing 35X80X34.9 MM | 1 | |
| 905,13 | 83 33 13 | | Ball bearing 20X52X15 MM | 1 | |
| 905,16 | 82 00 15 | | Hex.socket hd screw M6X20-A2-70 | 4 | |
| 905,23 | 85 03 17 | | O-ring 165.0 X 4.0 FPM | 1 | |
| 905,24 | 81 78 99 | | O-ring 74.61X3.53 NBR | 1 | |
| 905,26 | 82 59 03 | | Retaining ring SGA 35 | 1 | |
| 905,27 | 852 32 01 | | Shaft unit | 1 | |
| 905,63 | 836 39 00 | | Insulating hose | 1 | |
| 905 | 810 84 07 | (Ex) | Motor unit Maximum power: 2,20 kW / 3 HP Maximum current: 5,30 A Maximum power: 1,50 kW / 2 HP Maximum current: 3,90 A Maximum power: 3 kW / 4 HP Maximum current: 6,50 A Maximum power: 4 kW / 5,50 HP Maximum current: 8 A | | 1 |
| 905,7 | 810 62 07 | | Stator housing unit | | 1 |
| 905,8 | 826 29 01 | | Bearing holder | | 1 |
| 905,10 | 810 55 00 | | Retaining ring | | 1 |
| 905,11 | 797 44 00 | | Bearing cover | | 1 |
| 905,12 | 83 30 17 | | Ball bearing 35X80X34.9 MM | | 1 |
| 905,13 | 83 33 13 | | Ball bearing 20X52X15 MM | | 1 |
| 905,16 | 82 00 15 | | Hex.socket hd screw M6X20-A2-70 | | 4 |
| 905,23 | 85 03 17 | | O-ring 165.0 X 4.0 FPM | | 1 |
| 905,24 | 81 78 99 | | O-ring 74.61X3.53 NBR | | 1 |
| 905,26 | 82 59 03 | | Retaining ring SGA 35 | | 1 |
| 905,27 | 852 32 01 | | Shaft unit | | 1 |
| 905,63 | 836 39 00 | | Insulating hose | | 1 |



ООО «Бауманс Груп» - официальный партнер фирмы Flygt в России.

Тел: +7 495 121 49 50

Эл. почта: info@baumgroup.ru

Сайт: baumgroup.ru